

PARTS LIST AND SERVICE INFORMATION FOR PHILCO-TROPIC RADIO MODELS 3010 and 3010-I, CODES 123, 124, and 125

REPLACEMENT PARTS LIST

NOTE: Part numbers identified by an asterisk (*) are general replacement items. These numbers may not be identical with those on factory parts. Also, the electrical values of some replacement items may differ from the values indicated in the schematic diagram and parts list. The values substituted in any case are so chosen that the operation of the equipment will either be unchanged or improved. When ordering replacements, use only the "Service Part No." DO NOT USE THE REFERENCE SYMBOL.

Reference Symbol	Description	Service Part No.
C1	Condenser, aerial isolating, .0022 μ f.	45-3505-54*
C2	Condenser, fixed trimmer, 5 μ f.	30-1224-28
C3	Condenser, tuning, 2-section	31-2757
C3A	Condenser, trimmer, aerial	Part of C3
C3B	Condenser, trimmer, osc.	Part of C3
C4	Condenser, a-v-c isolating, 100 μ f.	62-110009001*
C5	Condenser, d-c blocking, 56 μ f.	62-056409001*
C6	Condenser, trimmer, 2-section	31-6476-23
C6A	Condenser, padder, osc.	Part of C6
C6B	Condenser, trimmer, osc. (bc.)	Part of C6
C7	Condenser, screen by-pass, .047 μ f.	45-3505-28*
C8	Condenser, a-v-c filter, .047 μ f.	45-3505-28*
C9	Condenser, d-c blocking, .0068 μ f.	45-3535-40*
C10	Condenser, d-c blocking, .0068 μ f.	45-3505-40*
C11	Condenser, grid by-pass, 220 μ f.	62-122001001
C12	Condenser, tone compensation, .033 μ f.	45-3505-44*
C13	Condenser, electrolytic, 3-section	30-2570-50
C13A	Condenser, filter, 20 μ f.	Part of C13
C13B	Condenser, filter, 25 μ f.	Part of C13
C13C	Condenser, filter, 30 μ f.	Part of C13
C14	Condenser, line by-pass, .05 μ f.	45-3505-52
I1	Lamp, pilot	34-2068
J1	Socket	27-6252-6
J2	Jack, a-c	27-6240-1
LS1	Speaker, p-m, Code 124	36-1625-14
	Speaker, p-m, Codes 123, 125	36-1627-10
P1	Plug, male, a-c	Part of W1
P2	Plug, a-c line	Part of W1
P3	Plug, shorting	27-4785-14
R1	Resistor, bc, primary loading, 22,000 ohms	66-3228340*
R2	Resistor, a-v-c load, 1 megohm	66-5108340*
R3	Resistor, grid return, 33,000 ohms	66-3338340*
R4	Resistor, special surge limiting	33-1343-3
R5	Resistor, screen filter, 4700 ohms	66-2478340
R6	Resistor, diode load, 2.2 megohms	66-5228340*
R7	Resistor, volume control (with off-on switch) 500,000 ohms, Codes 123, 125	33-5566-4
	Resistor, volume control (with off-on switch), 500,000 ohms, Code 124	33-5566-32
R8	Resistor, grid return, 10 megohms	66-6108340*
R9	Resistor, plate load, 470,000 ohms	66-4478340*
R10	Resistor, grid return, 470,000 ohms	66-4478340*
R11	Resistor, cathode bias, 150 ohms	66-1158340
R12	Resistor, filter, 1000 ohms	66-2108340
R13	Resistor, filter, 100 ohms	66-1104340

Reference Symbol	Description	Service Part No.
S1	Switch, band	42-1917
S2	Switch, power on-off	Part of R7
T1	Transformer, aerial	32-4431
T2	Transformer, osc.	32-4462-1
T3	Transformer, output	Part of LS1
TC1A	Tuning core, 1st i-f pri.	Part of Z1
TC1B	Tuning core, 1st i-f sec.	Part of Z1
TC2A	Tuning core, 2nd i-f pri.	Part of Z2
TC2B	Tuning core, 2nd i-f sec.	Part of Z2
W1	Line cord	41-3865
Z1	Transformer, 1st i-f	32-4377-2
Z2	Transformer, 2nd i-f	32-4378

MISCELLANEOUS

Description	Service Part No.
Cabinet, brown, Codes 123, 124	10769-1
Cabinet, brown, Code 125	10875-1
Cabinet, ivory, Codes 123, 124	10769-2
Back	54-8048
Fastener, back (4), Code 123	W-2235-2FA9
Fastener, back (4), Code 124	W-2235-FA9
Baffle and-cloth assembly, Codes 123, 124	40-7778-1
Baffle and-cloth assembly, Code 125	40-8578
Dial scale	54-5121
Strap, scale (r.h.)	56-7373-1FE11
Strap, scale (l.h.)	56-7373-FE11
Grille, plastic, Codes 123, 124	54-4728-2
Speed clip (4)	1W58920FE7
Knob, brown (2), Codes 125, 123	54-4718-2
Knob, brown (2), Code 124	54-4718-16
Knob, ivory (2), Codes 125, 123	54-4718-14
Knob, ivory (2), Code 124	54-4718-20
Knob, short-wave switch	54-4527-28
Dial-backplate assembly	76-6338
Dial cord, 25-foot spool	45-8750*
Spring, gang drive	28-8954
Spring, pointer drive	28-8953
Dial pointer	53-5630-34
Pilot-lamp assembly	27-6233-2
Plug, a-c adapter (continental)	L-3275
Socket, miniature (5)	27-6203
Tuning-shaft assembly, Code 124	31-2738-9
Tuning-shaft assembly, Codes 123, 125	31-2738-3

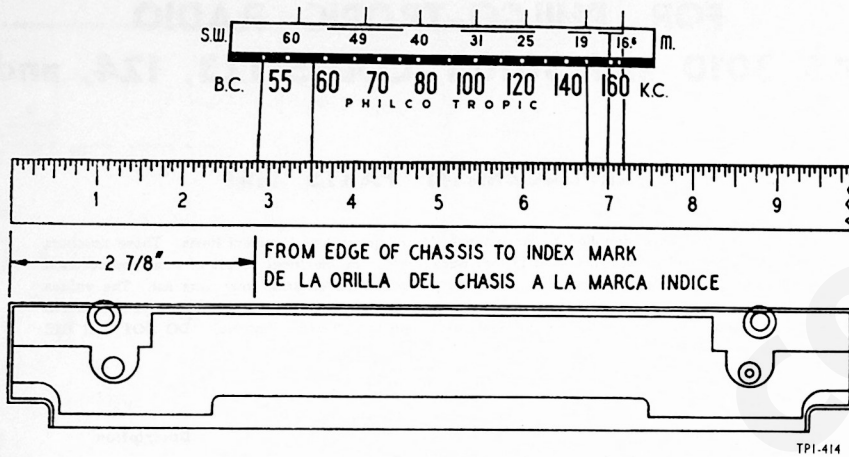

Figure 1. Dial-Calibration Measurements
Figura 1. Medidas para la Calibración del Cuadrante

TPI-414

ALIGNMENT

DIAL POINTER — With the tuning-condenser plates fully meshed, adjust the dial pointer to coincide with the index mark in the left-hand corner of the dial (just to the left of the "55" mark).

SIGNAL GENERATOR — Connect the ground lead to the chassis, through a .01- μ f. isolating condenser, and the output lead as indicated in the chart. Use modulated output.

RADIO CONTROLS — Set the volume control to maximum. Set the band switch, tuning control, and signal-generator frequency as indicated in the chart.

OUTPUT METER — Connect between the lugs indicated on the rear of the chassis.

OUTPUT LEVEL — During alignment, the signal-generator output must be attenuated to hold the output-meter reading below 1.5 volts.

ALINEAMIENTO

INDICADOR DEL CUADRANTE — Con el condensador de sintonización completamente cerrado, ajústese el indicador del cuadrante de modo que coincida con la marca índice en la esquina izquierda del cuadrante (a la izquierda del "55").

GENERADOR DE SEÑALES — Conéctese el cable de tierra al chasis, a través de un condensador de .01 μ f., y el cable de salida como se indica en la tabla. Use salida modulada.

CONTROLES DEL RADIO — Póngase el control de volumen al máximo. Fijense el conmutador de bandas, el control de sintonización y la frecuencia del generador de señales como se indica en la tabla.

MEDIDOR DE SALIDA — Conéctese a los terminales indicados en la parte posterior del chasis.

INTENSIDAD DE LA SALIDA — Durante el alineamiento, aténuese la salida del generador de señales para que la indicación en el medidor sea siempre menor de 1.5 voltios.

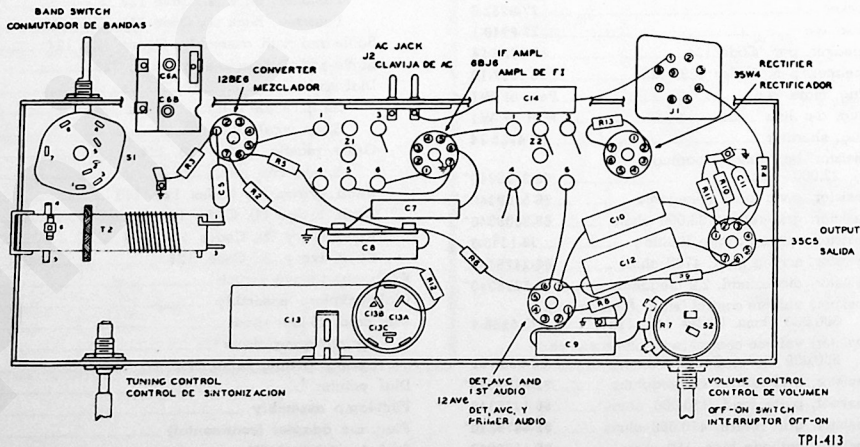
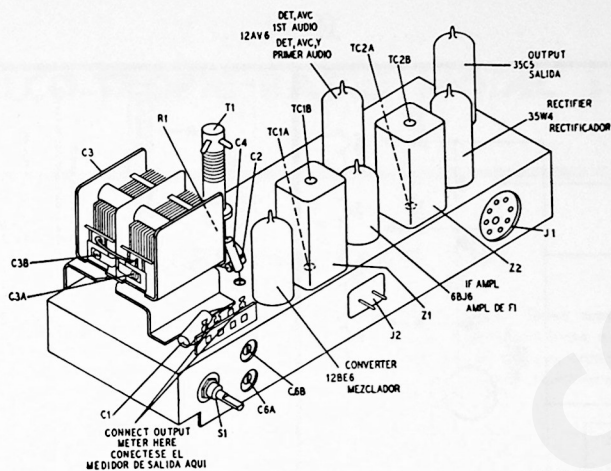

Figure 2. Symbolized Chassis, Showing Parts Placement
Figura 2. Vista del Chasis, Mostrando la Ubicación de las Partes

TPI-413



TP9-1210-1

Figure 3. Top View of Chassis, Showing Trimmer Locations
 Figura 3. Vista Superior del Chasis, Mostrando la Posición de los Compensadores

STEP PASO	SIGNAL GENERATOR GENERADOR DE SEÑALES		RADIO			ADJUST AJUSTENSE
	CONNECTION TO RADIO CONEXION AL RADIO	DIAL SETTING FRECUENCIA	BAND SWITCH CONMUT. DE BANDAS	DIAL SETTING FRECUENCIA	SPECIAL INSTRUCTIONS INSTRUCCIONES ESPECIALES	
1	Through .1 μ f. condenser to rear section of tuning condenser. A la sección posterior del cond. de sintonización, a través de un cond. de .1 μ f.	455 kc.	BC	580 kc.	Adjust, in order given, for maximum output; then repeat. Ajustense, en el orden dado, para salida máxima; luego repitase.	TC2B (2nd i-f sec.) TC2A (2nd i-f pri.) TC1B (1st i-f sec.) TC1A (1st i-f pri.)
2	Through 400-ohm resistor to aerial lead. Al alambre de antena, a través de una resist. de 400 ohms.	18 mc.	SW	16.6 meters	Adjust for maximum output. Ajustese para salida máxima.	C3B (SW osc.)
3	Same as step 2. Igual que el paso 2.	17 mc.	SW	17.6 meters	Adjust for maximum output. Ajustese para salida máxima.	C3A (ant. SW)
4	Through 200 μ f. condenser to aerial lead. Al alambre de antena, a través de un cond. de 200 μ f.	1500 kc.	BC	1500 kc.	Adjust for maximum output. Ajustese para salida máxima.	*C6B (BC osc.)
5	Same as step 4. Igual que el paso 4.	580 kc.	BC	580 kc.	Adjust for maximum output. Ajustese para salida máxima.	*C6A (BC osc. tracking)
6	Repeat step 4. Repitase el paso 4.					

*Rock tuning condenser while adjusting.

*Muévase el condensador de sintonización levemente de un lado a otro mientras se hace este ajuste.

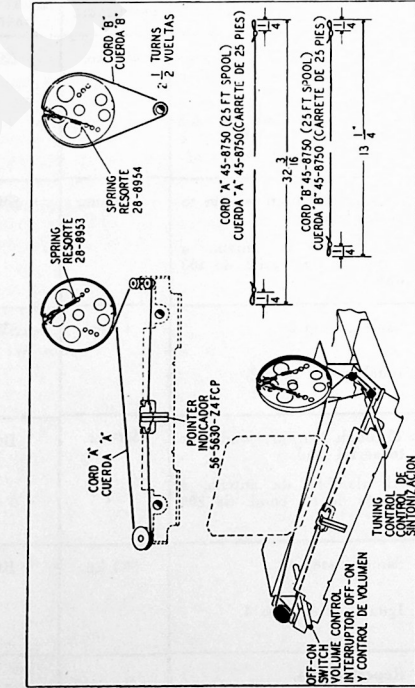
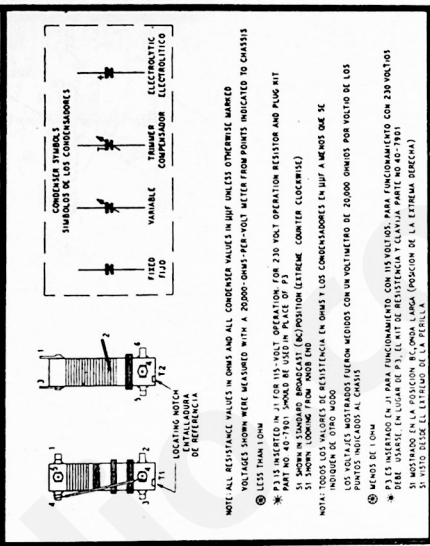
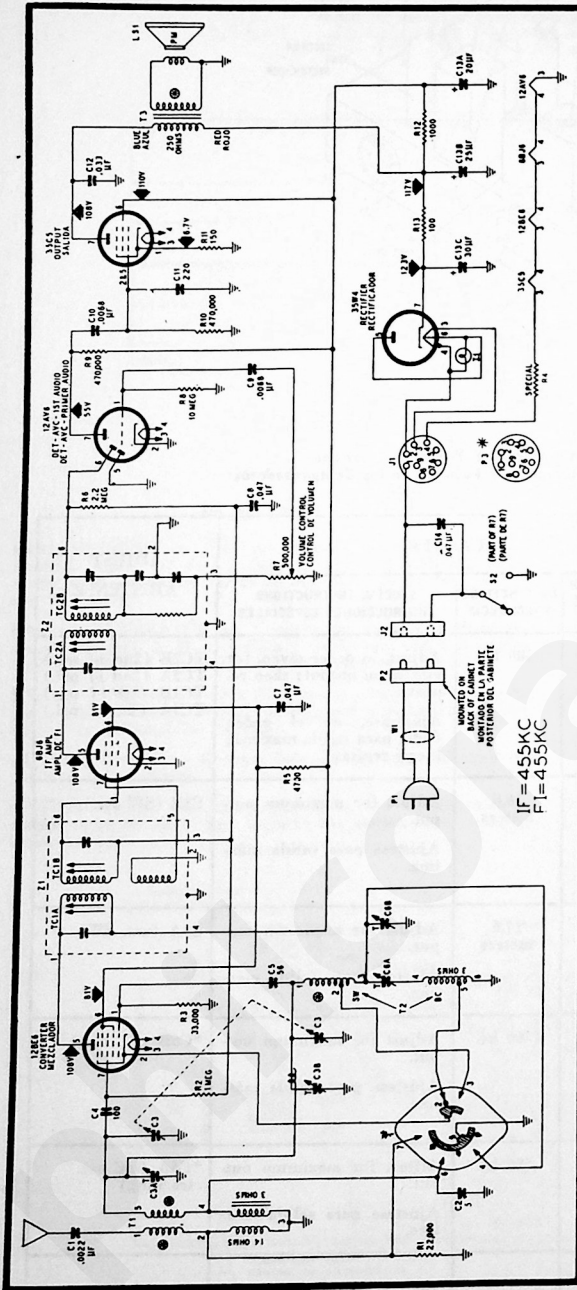

Figure 4. Philco-Tropic Radio Models 3010 and 3010I, Codes 123, 124, 125, Schematic Diagram

Figure 5. Drive-Cord Installation Details